

## SCS + CB-SCS

### CENTRAL FILTER SYSTEM WITH CONTROL BOX

The SCS is a floor-mounted filter unit that provides filtration for use in multiple arm systems from 3-15 extraction arms or general filtration systems. Extraction can be done by single fans or a central fan. The SCS is supplied in four different versions as far as the airflow direction is concerned. Connection of either a 0° or 90° air inlet module makes a total of eight possible air inlet positions.

The SCS is fitted with a *RoboCleanPlus* system for automatic section wise cleaning of the filter cartridge by compressed air. The dust and dirt particles end up in the drum underneath. A main filter cartridge, pre-separator (for multiple arm systems only), inlet module and control box have to be selected separately.



#### APPLICATIONS

The SCS is intended to be used for the following applications:

- MIG-MAG/GMAW welding
- TIG welding
- FCAW welding
- stick/MMAW welding



Do **not** use the SCS for the following applications or in the following circumstances:

- arc-air gouging
- aluminium laser cutting
- oil mist
- heavy oil mist in welding fume
- extraction of aggressive fumes and gases (e.g. from acids, from alkaline, from soldering paste containing lithium)
- extraction of hot gases (more than 45°C/113°F continuously)
- grinding aluminum and magnesium
- flame spraying
- extraction of cement, saw dust, wood dust etc.
- sucking cigarettes, cigars, oiled tissues and other burning particles, objects and acids
- explosive environments or explosive substances/gases



#### SPECIFICATIONS

##### Physical dimensions and properties

Material:	<ul style="list-style-type: none"> <li>• Filter housing</li> <li>• Base</li> </ul>	<ul style="list-style-type: none"> <li>• steel</li> <li>• LMDPE (linear medium density polyethylene)</li> </ul>
Frame		<ul style="list-style-type: none"> <li>• steel</li> </ul>
Colour:	<ul style="list-style-type: none"> <li>• Filter housing</li> <li>• Base</li> <li>• Frame</li> </ul>	<ul style="list-style-type: none"> <li>• grey RAL 7035</li> <li>• grey RAL 7024</li> <li>• black RAL 9005</li> </ul>
Weight (net)		260 kg (573 lbs)
Drum contents		100 litres (26 gallon)
Required floor space SCS + PSC + SIF-1200 LI/RI		min. 325 x 137 cm (128 x 54 in.)

##### Filters

Material:	<ul style="list-style-type: none"> <li>• FCC-150</li> <li>• FCP-110</li> </ul>	<ul style="list-style-type: none"> <li>• 78% cellulose, 22% resin</li> <li>• polyester</li> </ul>
-----------	--	---

Treatment	SurfacePlus precoat on filter cartridge FCC-150	
Filter surface area:	<ul style="list-style-type: none"> <li>• FCC-150</li> <li>• FCP-110</li> </ul>	<ul style="list-style-type: none"> <li>• 2 x 75 m<sup>2</sup> (2 x 807 ft<sup>2</sup>)</li> <li>• 2 x 55 m<sup>2</sup> (2 x 592 ft<sup>2</sup>)</li> </ul>
Filter class according to DIN EN 60335-2-69:	<ul style="list-style-type: none"> <li>• FCC-150</li> <li>• FCP-110</li> </ul>	<ul style="list-style-type: none"> <li>• L</li> <li>• M</li> </ul>
<b>RoboCleanPlus filter cleaning system</b>		
Required compressed air quality	dry and oil-free according to ISO 8573-3 class 6	
Required pressure	6 bar (2400" WG)	
Compressed air connection	quick connection coupling Ø 9 mm (CEJN 320)	
Compressed air consumption	max. 150 nl/min. (5.3 ft <sup>3</sup> /min.) (depending on the degree of saturation of the filter)	
Duration off-line cleaning cycle	approx. 1 hour	
<b>Performance</b>		
Capacity	max. 9000 m <sup>3</sup> /h	
<b>Electrical data</b>		
Power consumption	50 W	
Connection voltage	230/400V/1-3~/50Hz	
Protection class	IP 55	
<b>Ambient conditions</b>		
Operating temperature:	<ul style="list-style-type: none"> <li>• Min. 5°C (41°F)</li> <li>• Nom. 20°C (68°F)</li> <li>• Max. 45°C (113°F)</li> </ul>	
Max. relative humidity	75%	
Outdoor use allowed	yes, if protected against rain	
Storage conditions	<ul style="list-style-type: none"> <li>• 5-45°C (41-113°F)</li> <li>• relative humidity max. 75%</li> </ul>	

■ Product combinations	
FCC-150	cellulose filter cartridge (two-piece)
FCP-110	polyester filter cartridge (two-piece)
PSC	pre-separator
Inlet-0°/90°	air inlet module
CB-SCS	control box
CB-SCS/PLC	control box with PLC
■ Scope of supply	
Assembled SCS filter unit (air inlet module, filter cartridges, control box) - Frame - Drum - Hardware	
■ Order information	
Article numbers:	
• 7455000000	• SCS (1)
• 7455010000	• SCS (2)
• 7455020000	• SCS (3)
• 7455030000	• SCS (4)
• 9850060080	• FCC-150
• 9850060100	• FCP-110
• 9850070010	• PSC
• 9850032000	• Inlet-0°
• 9850032010	• Inlet-90°
• 7900020340	• CB-SCS
• 7900020420	• CB-SCS/PLC
Number/package	1
■ Shipping data	
Gross weight (incl. pallet)	
Packing dimensions	
Max. number/pallet	1
Harmonized Tariff Code	8537.1091.90
Country of origin	the Netherlands



## DIMENSIONS

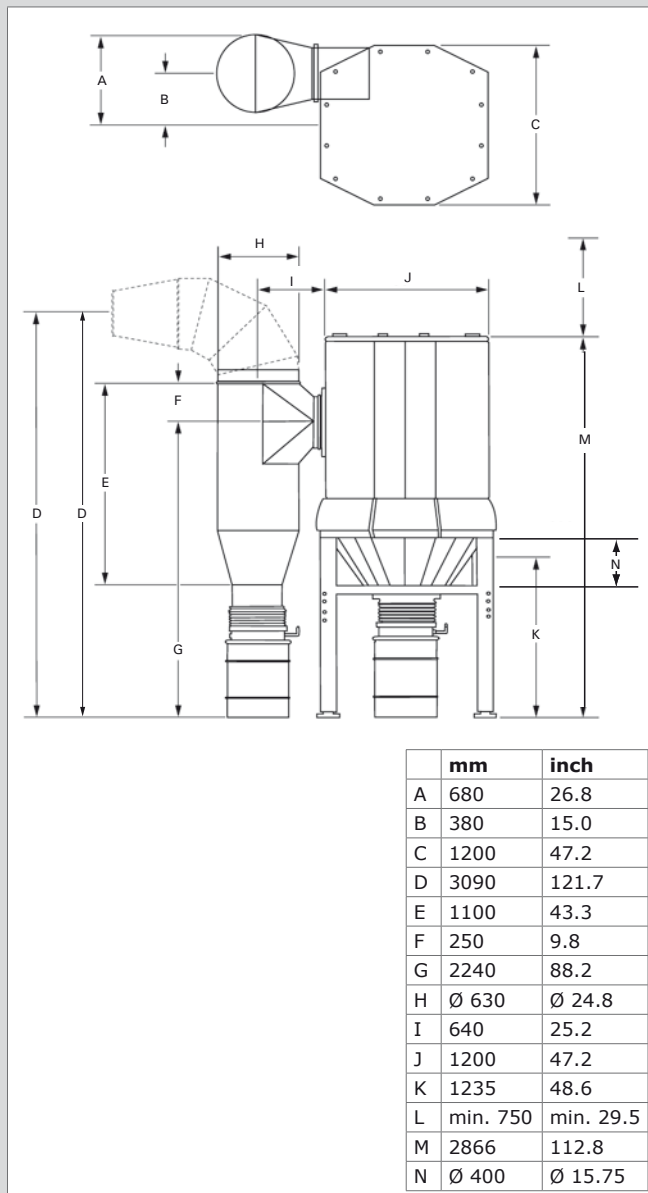

## APPROVALS/CERTIFICATES



EU Directive 2002/95/EC  
(RoHS) (valid as of July 2006)

## FEATURES

*RoboCleanPlus* automatic filter cleaning system



Product type  
Article no.  
Product category  
Version

**SCS + CB-SCS**  
refer to order information  
central filter systems  
281010/C

Always check the latest version on [www.plymovent.com](http://www.plymovent.com).